

Temperature Compensator

1/4", 1 1/2" & 2" Type 4D & 4D-MT

Index	Descriptio	Part #		
		1 1/4"	1 1/2"	2"
1	Screw, cover	9287-003		
2	Mounting plate & lever arm assy.	86649-003		
3	Pin, lever arm lock	86661-001		
4	Cotter pin, 1/16" dia. x 3/8", brass	86973-000	86973-00	86973-000
5	Pin, thermostat	86648-000		
6	Thermostat Bellows	86646-000		
7	O-ring	100139-005		
8	Thermometer well complete	1001906		
9	Cover	83732-000		
10	Screw, 1/4-20 x 2 1/2, fil hd steel	8302-107		
11	Lockwasher, 1/4" steel, small	88721-000		
12	Adapter unit complete	86602-005		
13	Star assembly	82976-001		
14	Adapter	85006-000	-	
15	Gear train complete	83501-000	84981-000	83502-000
16	Nut stuffing box	83536-000		
17	U-cup, shaft seal	100025-002		
18	Expander	83539-000		
19	Stuffing box spring	83540-000		
20	O-ring	100138-003		
21	Mounting stud	84435-000		
-	Compensator complete	86600-201	86600-204	86702-301

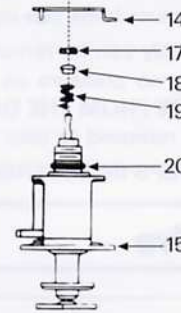
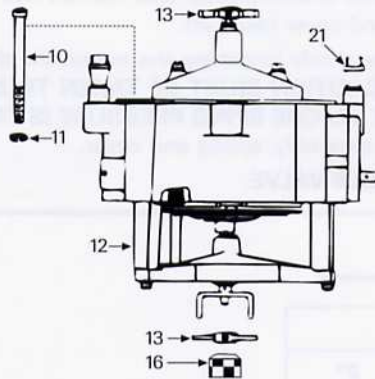
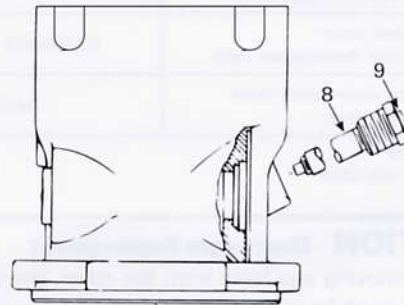
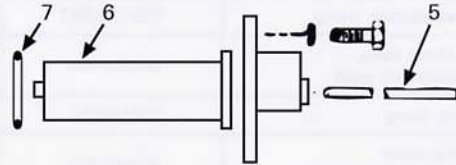
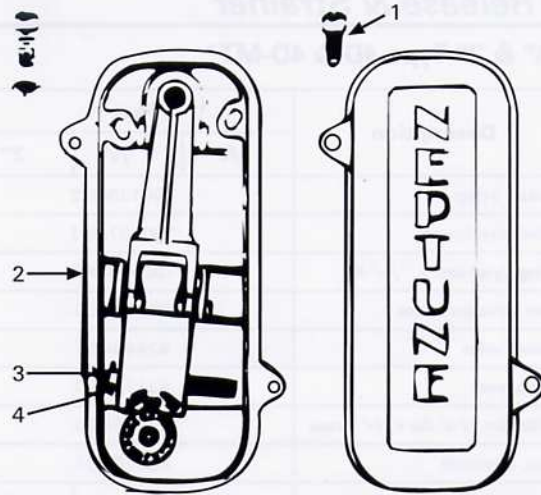

Measuring Chamber

Index	Description	Part #		
		1 1/4"	1 1/2"	2"
1	Gasket	4862-008		
2	Measuring chamber complete	43260-101	83271-101	45806-101
3	Diaphragm	43271-000	83277-000	42312-001
4	Roller, control	43275-000		
5	Diaphragm Roller Kit	43260-702	83271-702	45806-701
6	Complete Seal Kit	101757-001		101758-001

